

SkyLine Premium Electric Combi Oven 20GN2/1, 230V

ITEM # _____

MODEL # _____

NAME # _____

SIS # _____

AIA # _____

217819 (ECO202B3C30)

SkyLine Premium Combi Boiler Oven with digital control, 20x2/1GN, electric, programmable, automatic cleaning, boiler in AISI 316L, 3-glass door - 230V

Short Form Specification

Item No.

- Combi oven with digital interface with guided selection.
- Built-in steam generator (in s/s 316L) with real humidity control based upon Lambda Sensor.
 - OptiFlow air distribution system to achieve maximum performance with 5 fan speed levels.
 - SkyClean: Automatic and built-in self cleaning system with integrated descale of the steam generator. metterei 4 automatic cycles (short, medium, intensive, rinse) .
 - Cooking modes: Programs (a maximum of 100 recipes can be stored); Manual (steam, combi and convection cycles); EcoDelta cooking cycle; Regeneration cycle.
 - Automatic backup mode to avoid downtime.
 - USB port to download HACCP data, programs and settings
 - Connectivity for real time access, HACCP, recipe and energy management (optional)
 - Single sensor core temperature probe.
 - Triple-glass door with double LED lights line.
 - Stainless steel construction throughout.
 - Supplied with n.1 trolley rack 2/1 GN, 63 mm pitch.
 - Adjustable levelling feet.

Main Features

- Built-in steam generator for highly precise humidity and temperature control according to the chosen settings.
- Real humidity control based upon Lambda Sensor to automatically recognize quantity and size of food for consistent quality results.
- Dry, hot convection cycle (25 °C - 300 °C): ideal for low humidity cooking.
- Short cleaning cycle: optimized cleaning cycle with a duration of just 33 minutes, improving efficiency and reducing downtime.
- Combination cycle (25 °C - 300 °C): combining convected heat and steam to obtain humidity controlled cooking environment, accelerating the cooking process and reducing weight loss.
- Low temperature Steam cycle (25 °C - 99 °C): ideal for sous-vide, re-thermalization and delicate cooking.
 Steam cycle (100 °C): seafood and vegetables.
 High temperature steam (101 °C - 130 °C).
- SkyClean: Automatic and built-in self cleaning system with 4 automatic cycles (short, medium, intensive, rinse) and integrated descale of the steam generator.
- EcoDelta cooking: cooking with food probe maintaining preset temperature difference between the core of the food and the cooking chamber.
- Pre-set program for Regeneration, ideal for banqueting on plate or rethermalizing on tray.
- Programs mode: a maximum of 100 recipes can be stored in the oven's memory, to recreate the exact same recipe at any time. 4-step cooking programs also available.
- OptiFlow air distribution system to achieve maximum performance in chilling/heating evenness and temperature control thanks to a special design of the chamber.
- Fan with 5 speed levels from 300 to 1500 RPM and reverse rotation for optimal evenness. Fan stops in less than 5 seconds when door is opened.
- Single sensor core temperature probe included.
- Automatic fast cool down and pre-heat function.
- Back-up mode with self-diagnosis is automatically activated if a failure occurs to avoid downtime.
- GreaseOut: integrated grease drain and collection kit (to use the kit, the oven must be ordered as special code).
- Electrolux Professional recommends the use of treated water to guarantee optimal cooking results and extend the life of the appliance. Check local water condition to select the appropriate water filter. More info available on the website.
- 6-point multi sensor core temperature probe for maximum precision and food safety (optional accessory).

Construction

- Boiler in 316L AISI to protect against corrosion.
- Triple thermo-glazed door with 2 hinged inside panels for easy cleaning and double LED lights line.

APPROVAL: _____

- Hygienic internal chamber with all rounded corners for easy cleaning.
- 304 AISI stainless steel construction throughout.
- Front access to control board for easy service.
- IPX5 spray water protection certification for easy cleaning.

User Interface & Data Management

- Connectivity for remote real time access, easy HACCP management, equipment uptime increase, consumption tracking and energy management (requires optional accessory).
- Digital interface with LED backlight buttons with guided selection.
- USB port to download HACCP data, share cooking programs and configurations. USB port also allows to plug-in sous-vide probe (optional accessory).

Sustainability



- Human centered design with 4-star certification for ergonomics and usability.
 - Wing-shaped handle with ergonomic design and hands-free opening with the elbow, making managing trays simpler. Protected by registered design (EM003143551 and related family).
 - The outer cardboard packaging is made from 70% recycled materials and FSC*-certified paper, printed with eco-friendly, water-based ink to support sustainability and environmental responsibility.
- <i>(*Forest Stewardship Council is the world's leading organization for sustainable forest management).</i>
- Triple-glass door minimize your energy loss.*
- *<i>Approx. -10% of idle energy consumption in convection based on test in compliance with ASTM Standard F2861-20</i>
- Save energy, water, detergent and rinse aid with SkyClean green functions.
 - C22 and C25 detergents are formulated without phosphates and phosphorus (C25 is also maleic acid-free), making them safe for both the environment and human health.
 - Reduced powerfunction for customized slow cooking cycles.
 - Energy Star 2.0 certified product.

Included Accessories

- 1 of Trolley with tray rack 20 GN 2/1, 63mm pitch PNC 922757

Optional Accessories

- External reverse osmosis filter for single tank Dishwashers with atmosphere boiler and Ovens PNC 864388
- Water filter with cartridge and flow meter for high steam usage (combi used mainly in steaming mode) PNC 920003
- Water filter with cartridge and flow meter for medium steam usage PNC 920005
- Pair of AISI 304 stainless steel grids, GN 1/1 PNC 922017
- Pair of grids for whole chicken (8 per grid - 1,2kg each), GN 1/1 PNC 922036
- AISI 304 stainless steel grid, GN 1/1 PNC 922062
- External side spray unit (needs to be mounted outside and includes support to be mounted on the oven) PNC 922171

- Baking tray for 5 baguettes in perforated aluminum with silicon coating, 400x600x38mm PNC 922189
- Baking tray with 4 edges in perforated aluminum, 400x600x20mm PNC 922190
- Baking tray with 4 edges in aluminum, 400x600x20mm PNC 922191
- Pair of frying baskets PNC 922239
- AISI 304 stainless steel bakery/pastry grid 400x600mm PNC 922264
- Grid for whole chicken (8 per grid - 1,2kg each), GN 1/1 PNC 922266
- Universal skewer rack PNC 922326
- 6 short skewers PNC 922328
- Volcano Smoker for lengthwise and crosswise oven PNC 922338
- Multipurpose hook PNC 922348
- Grease collection tray, GN 2/1, H=60 mm PNC 922357
- Grid for whole duck (8 per grid - 1,8kg each), GN 1/1 PNC 922362
- Thermal cover for 20 GN 2/1 oven and blast chiller freezer PNC 922367
- Wall mounted detergent tank holder PNC 922386
- USB single point probe PNC 922390
- IoT module for OnE Connected (Combi Ovens, Blast chiller/freezers, Rack Type DW) and SkyDuo (one IoT board per appliance - to connect oven to blast chiller for Cook&Chill process) PNC 922421
- Connectivity router (WiFi and LAN) PNC 922435
- Deflector for 20 GN 2/1 electric oven trolley PNC 922445
- Elevating kit with trolley height extension for 20 GN 2/1 oven PNC 922447
- External connection kit for liquid detergent and rinse aid PNC 922618
- Dehydration tray, GN 1/1, H=20mm PNC 922651
- Flat dehydration tray, GN 1/1 PNC 922652
- Heat shield for 20 GN 2/1 oven PNC 922658
- Trolley with tray rack, 15 GN 2/1, 84mm pitch PNC 922686
- Kit to fix oven to the wall PNC 922687
- 4 flanged feet for 20 GN , 2", 100-130mm PNC 922707
- Mesh grilling grid, GN 1/1 PNC 922713
- Probe holder for liquids PNC 922714
- Levelling entry ramp for 20 GN 2/1 oven PNC 922716
- Stainless steel drain kit for 20 GN oven, dia=50mm PNC 922738
- Plastic drain kit for 20 GN oven, dia=50mm PNC 922739
- Holder for trolley handle (when trolley is in the oven) for 20 GN oven PNC 922743
- Tray for traditional static cooking, H=100mm PNC 922746
- Double-face griddle, one side ribbed and one side smooth, 400x600mm PNC 922747
- Trolley with tray rack 20 GN 2/1, 63mm pitch PNC 922757
- Trolley with tray rack, 16 GN 2/1, 80mm pitch PNC 922758

- Banquet trolley with rack holding 92 plates for 20 GN 2/1 oven and blast chiller freezer, 85mm pitch PNC 922760
- Bakery/pastry trolley with rack holding 400x600mm grids for 20 GN 2/1 oven and blast chiller freezer, 80mm pitch (16 runners) PNC 922762
- Banquet trolley with rack holding 116 plates for 20 GN 2/1 oven and blast chiller freezer, 66mm pitch PNC 922764
- Kit compatibility for aos/easyline trolley (produced till 2019) with SkyLine/Magistar 20 GN 2/1 combi oven PNC 922770
- Kit compatibility for aos/easyline 20 GN oven with SkyLine/Magistar trolleys PNC 922771
- Water inlet pressure reducer PNC 922773
- Extension for condensation tube, 37cm PNC 922776
- Kit for installation of electric power peak management system for 20 GN Oven PNC 922778
- Non-stick universal pan, GN 1/1, H=40mm PNC 925001
- Non-stick universal pan, GN 1/1, H=60mm PNC 925002
- Double-face griddle, one side ribbed and one side smooth, GN 1/1 PNC 925003
- Aluminum grill, GN 1/1 PNC 925004
- Frying pan for 8 eggs, pancakes, hamburgers, GN 1/1 PNC 925005
- Flat baking tray with 2 edges, GN 1/1 PNC 925006
- Potato baker for 28 potatoes, GN 1/1 PNC 925008
- Kit of 6 non-stick universal pans, GN 1/1, H=20mm PNC 925012
- Kit of 6 non-stick universal pans, GN 1/1, H=40mm PNC 925013
- Kit of 6 non-stick universal pan GN 1/1, H=60mm PNC 925014

Recommended Detergents

- C25 Rinse & Descale Tabs, phosphate-free, phosphorous-free, maleic acid-free, 50 tabs bucket PNC 0S2394
- C22 Cleaning Tabs, phosphate-free, phosphorous-free, 100 bags bucket PNC 0S2395

Electric

Supply voltage:	220-240 V/3 ph/50-60 Hz
Electrical power, max:	70.2 kW
Electrical power, default:	65.4 kW

Water:

Inlet water temperature, max:	30 °C
Inlet water pipe size (CW11, CW12):	3/4"
Pressure, min-max:	1-6 bar
Chlorides:	<85 ppm
Conductivity:	>50 µS/cm
Drain "D":	50mm

Capacity:

Trays type:	20 (GN 2/1)
Max load capacity:	200 kg

Key Information:

Door hinges:	Right Side
External dimensions, Width:	1162 mm
External dimensions, Depth:	1066 mm
External dimensions, Height:	1794 mm
Weight:	386 kg
Net weight:	348 kg
Shipping weight:	386 kg
Shipping volume:	2.77 m ³

ISO Certificates

ISO Standards:	ISO 9001; ISO 14001; ISO 45001; ISO 50001
-----------------------	---

Front

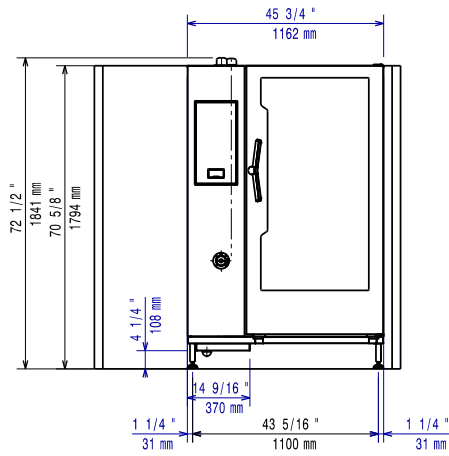

Side

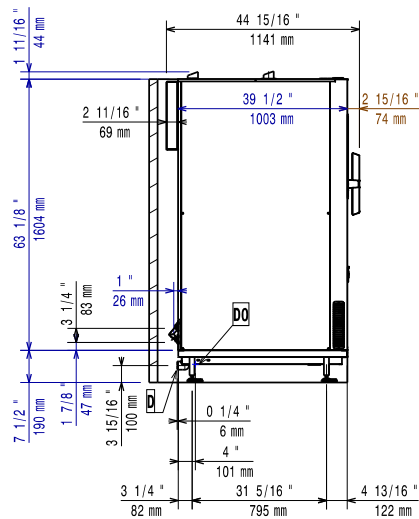

- CWI1 = Cold Water inlet 1 (cleaning) EI = Electrical inlet (power)
 CWI2 = Cold Water Inlet 2 (steam generator)
 D = Drain
 DO = Overflow drain pipe

Top

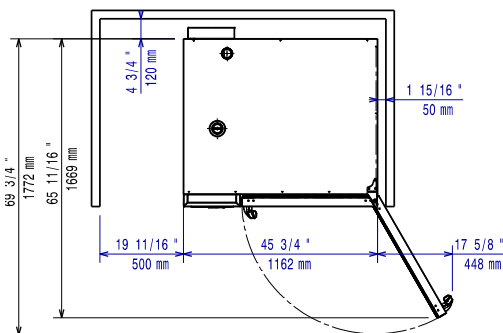

Distances

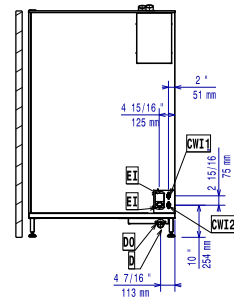

- CWI1 = Cold Water inlet 1 (cleaning) EI = Electrical inlet (power)
 CWI2 = Cold Water Inlet 2 (steam generator)
 D = Drain
 DO = Overflow drain pipe